

HTGR Technology Course for the Nuclear Regulatory Commission

May 24 – 27, 2010

Module 5a

Prismatic HTGR Core Design Description

Russell Vollman
General Atomics

Outline

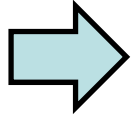

- **Core design description**
- **Cylindrical vs. annular core**
- **Coolant flow paths**
- **Central reflector options**
- **Effect of core outlet temperature on selection of materials**
- **Summary**

Reactors Essentially the Same between Steam & Gas Turbine Power Plants

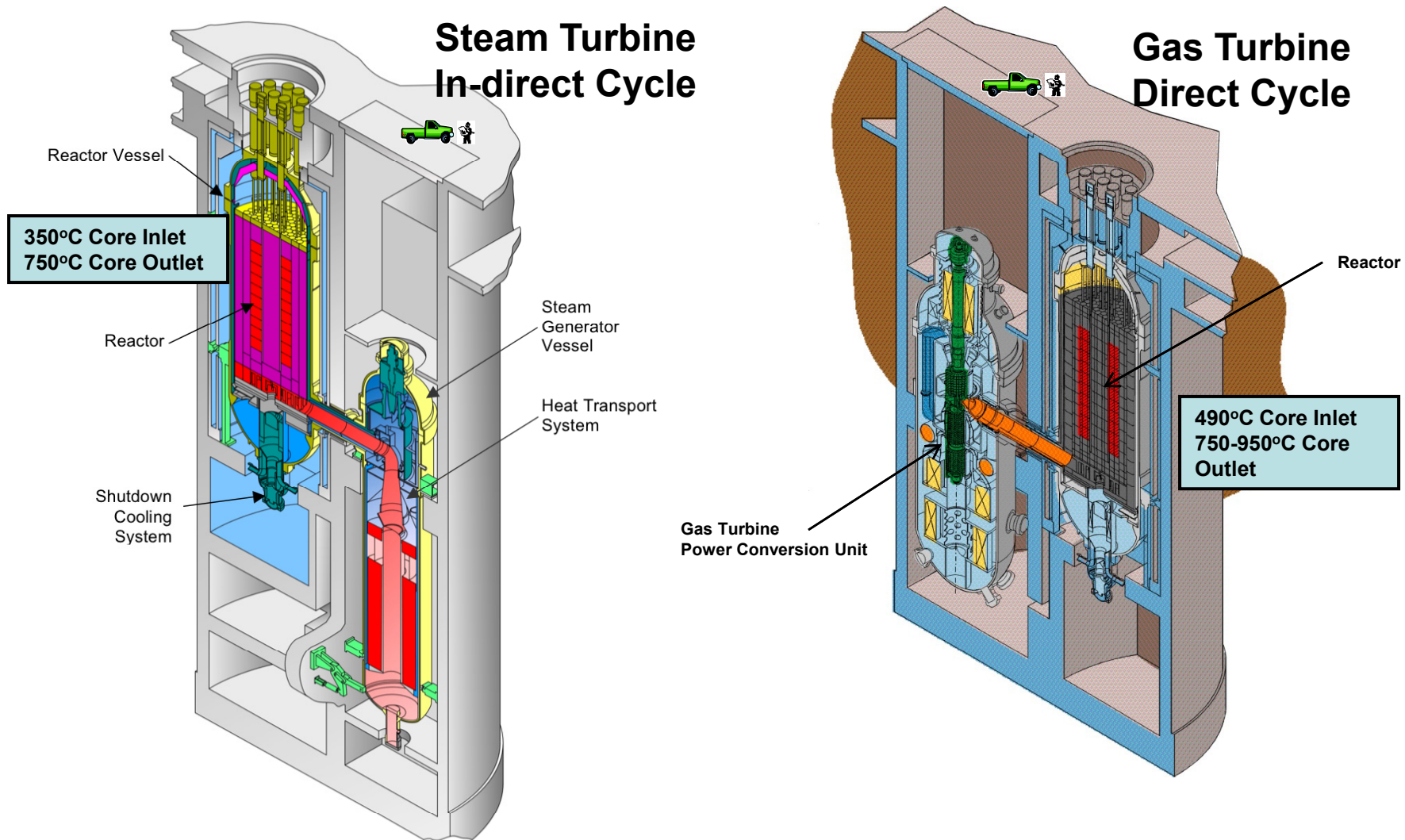

MHTGR Design Approach

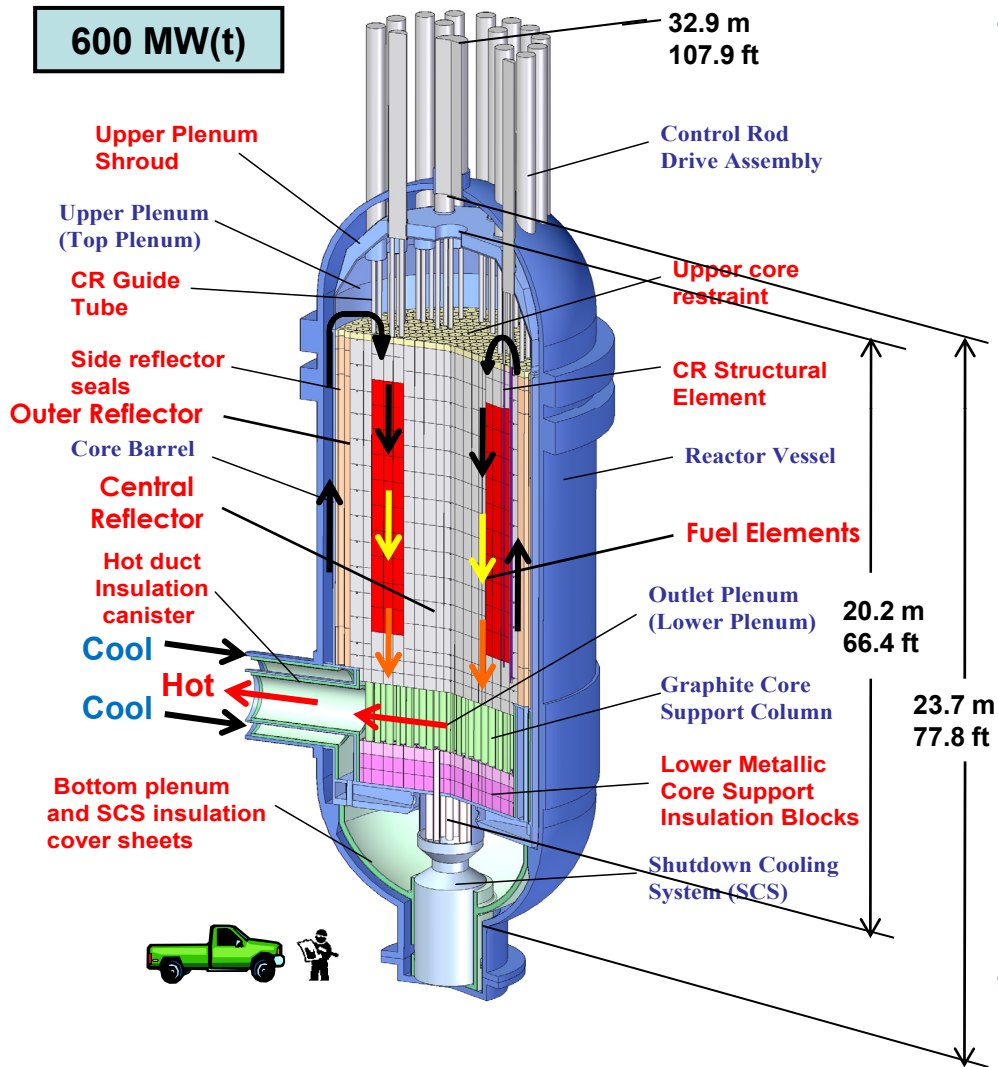

- **Passive safety features**
 - Negative temperature coefficient reduces reactivity as temperature rises
 - Helium coolant
 - Non-moderating
 - Gaseous phase during all conditions
 - Radioactively & chemically inert (can be carrier gas)
 - Ceramic coated-particle fuel
 - Maintains structural integrity during LOCA
 - Contains fission products during normal operation
 - Low power density (5.8-6.6 w/cc)
 - Maintain acceptable temperatures during normal operation and accidents
 - Annular graphite core with high heat capacity
 - Limits fuel temperature during LOCA (1600°C)
 - High temperature structural stability (Graphite sublimates ~3700°C)
 - High thermal inertia - long temperature rise time for LOCA
 - Cool reactor vessel & metallic internals with core inlet gas
- Use components successfully demonstrated in Fort St. Vrain Reactor

Basic Core Layout

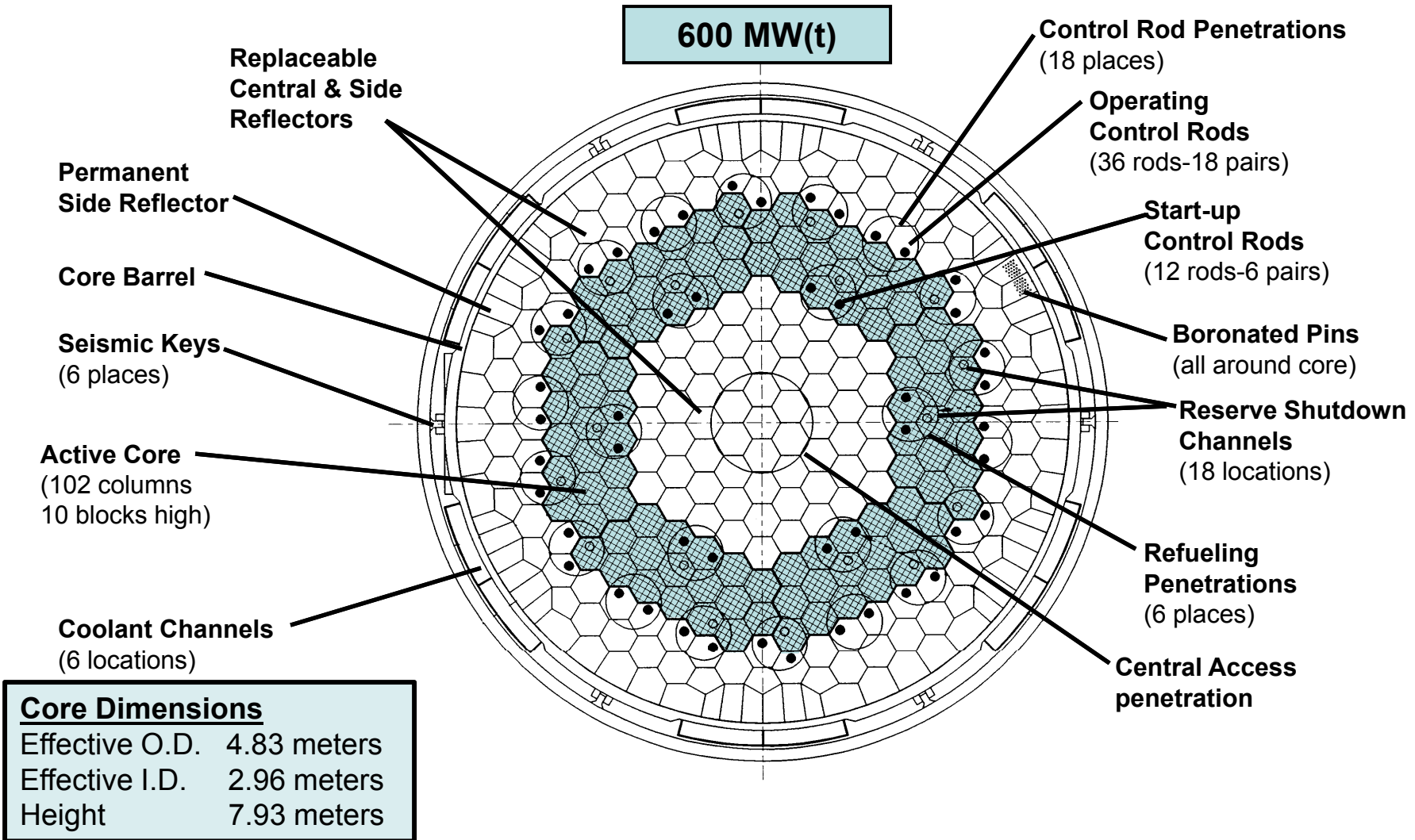

Fort St. Vrain Experience Incorporated into Design of Reactor Core & Internals Hardware

- Machining of graphite fuel elements optimized
- Performance of TRISO fuel particles as predicted
- Irradiation dimensional change of fuel elements within predictions using graphite material models
- Upper Core Restraint developed to stabilize fuel columns from flow induced movements
- Control rods performed as predicted
- Redundant and diverse reserve shutdown pellets developed and perfected

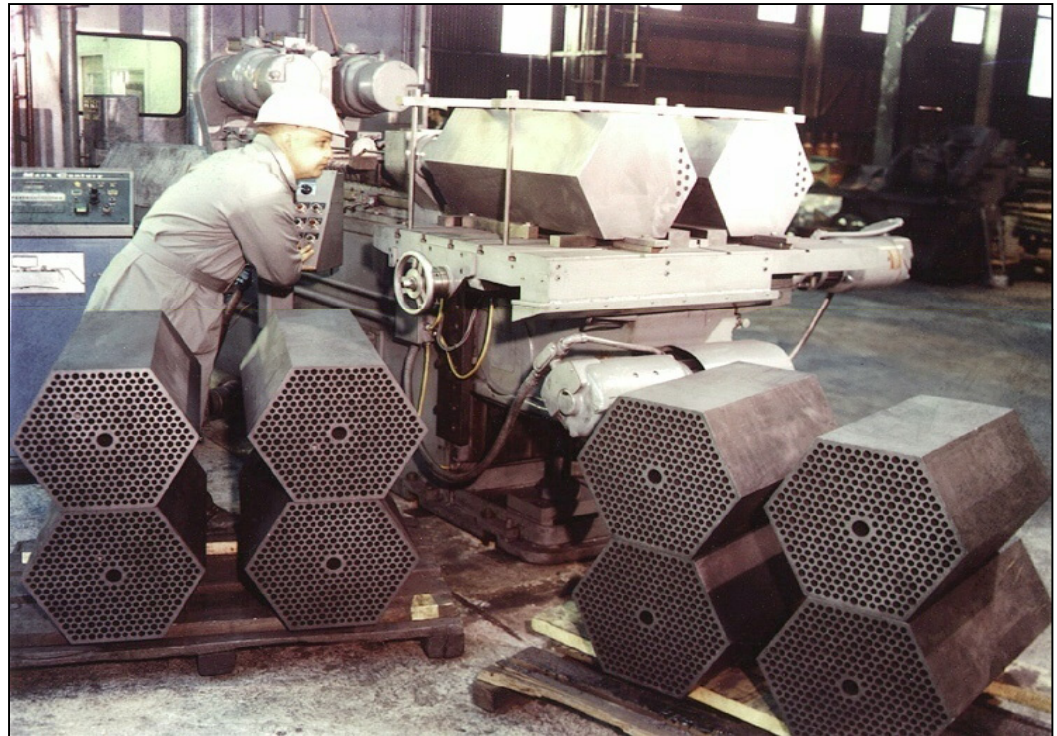

Gun drilling long holes in Ft. St. Vrain fuel elements
Today - drilled with numerically controlled machines

MHTGR / LWR Reactor Core Comparison

Item	MHTGR		LWR	
Moderator	Graphite	Single-phase	Water	2-phase
Coolant	Helium	Single-phase Lo-heat capacity	Water	2-phase Hi-heat capacity
Avg Coolant Exit temp	700-950°C	Hi-Plant Efficiency	310°C	Medium Plant Efficiency
Power Density	4 to 6.5 W/cc	Lo-Power Density	58 – 105 W/cc	Hi-Power Density
Linear Heat Rate	1.6 kW/ft	Lo-Linear heat rate	19 kW/ft	Hi-linear heat rate
Migration Length	57 cm	Control Rods far apart Lumped Burnable poison	6 cm	Control rods close together Boronated Water Poison
Structural Mat'l	Graphite	2700°C useful 3700°C max Sublimates	Steel X750	816°C useful 1400°C Melt
Fuel Clad	SiC PyC	~1800°C useful ~2000°C max 2700°C Sublimates 2700°C Useful 3700°C sublimates	Zircaloy	1200°C useful 1767°C melt
Fuel	UO ₂ /UCO	2790°C melt	UO ₂	2847°C melt
Fuel Damage Temp	>1800°C	Hi-Temp Damage limit	1260°C	Medium-Temp Damage limit

Core Composed of Basic Structural Units

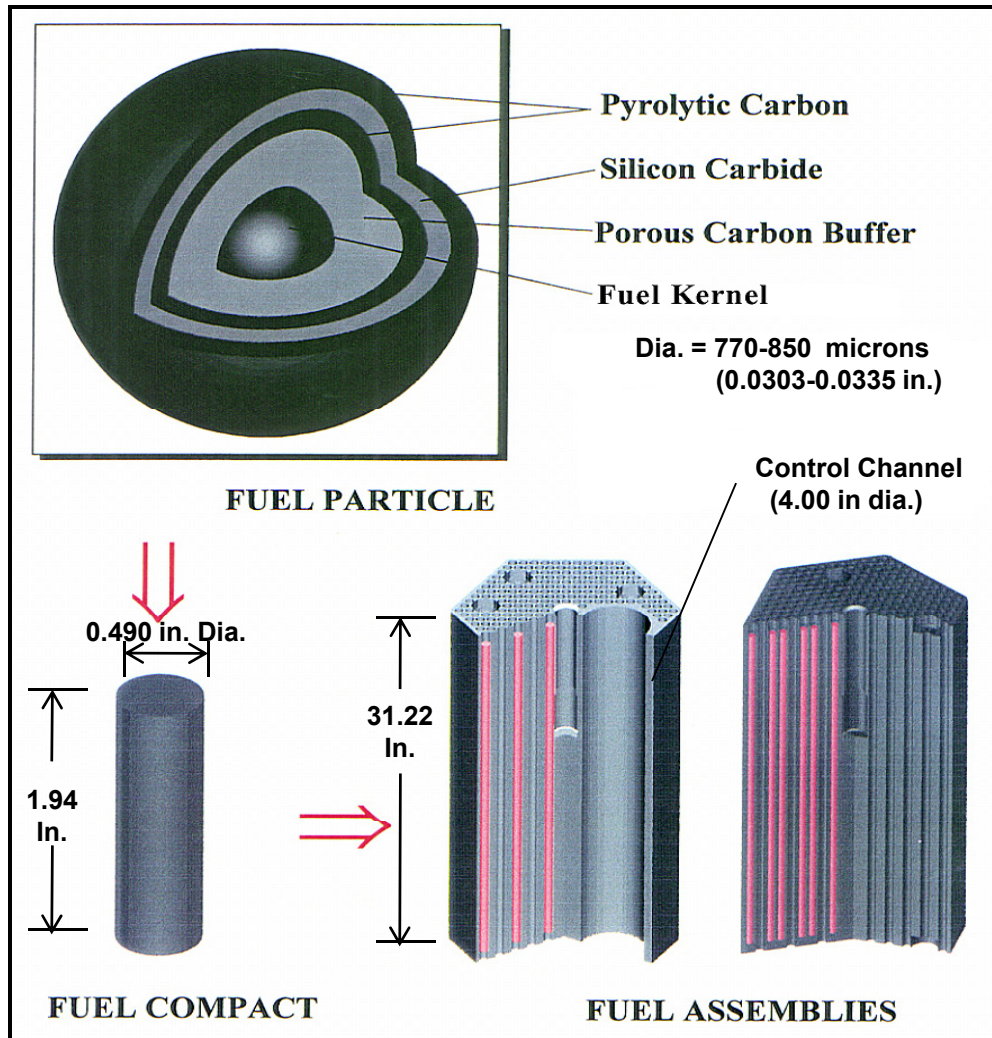

- Fuel particle SiC and PyC coatings retain fission products
- Fuel compact contains 4,000 to 7,000 particles
- Graphite block supports fuel compacts in arrangement compatible with nuclear reaction and heat transfer to helium
 - 14/15 fuel compacts per fuel hole
 - 210 fuel holes per fuel assembly
 - 3126 Rods per fuel assembly
 - 12.5 to 21.9 million fuel particles per fuel assembly
 - Graphite element weight = 90kg
 - Fuel assembly weight = 122kg
 - Avg. thermal power/element = 0.59 MW(t)
- Inner control rods & reserve shutdown channels in some fuel assemblies
- Dowels align coolant holes & control rod channels between blocks

Fuel Rod/Coolant Hole Pattern Optimized

Objectives:

- Remove heat as close to source as possible
- Maintain fuel compact centerline temperature <1250°C (short time excursions to 1400°C)
- Optimize reactor core pressure drop
- Maintain graphite element structural integrity

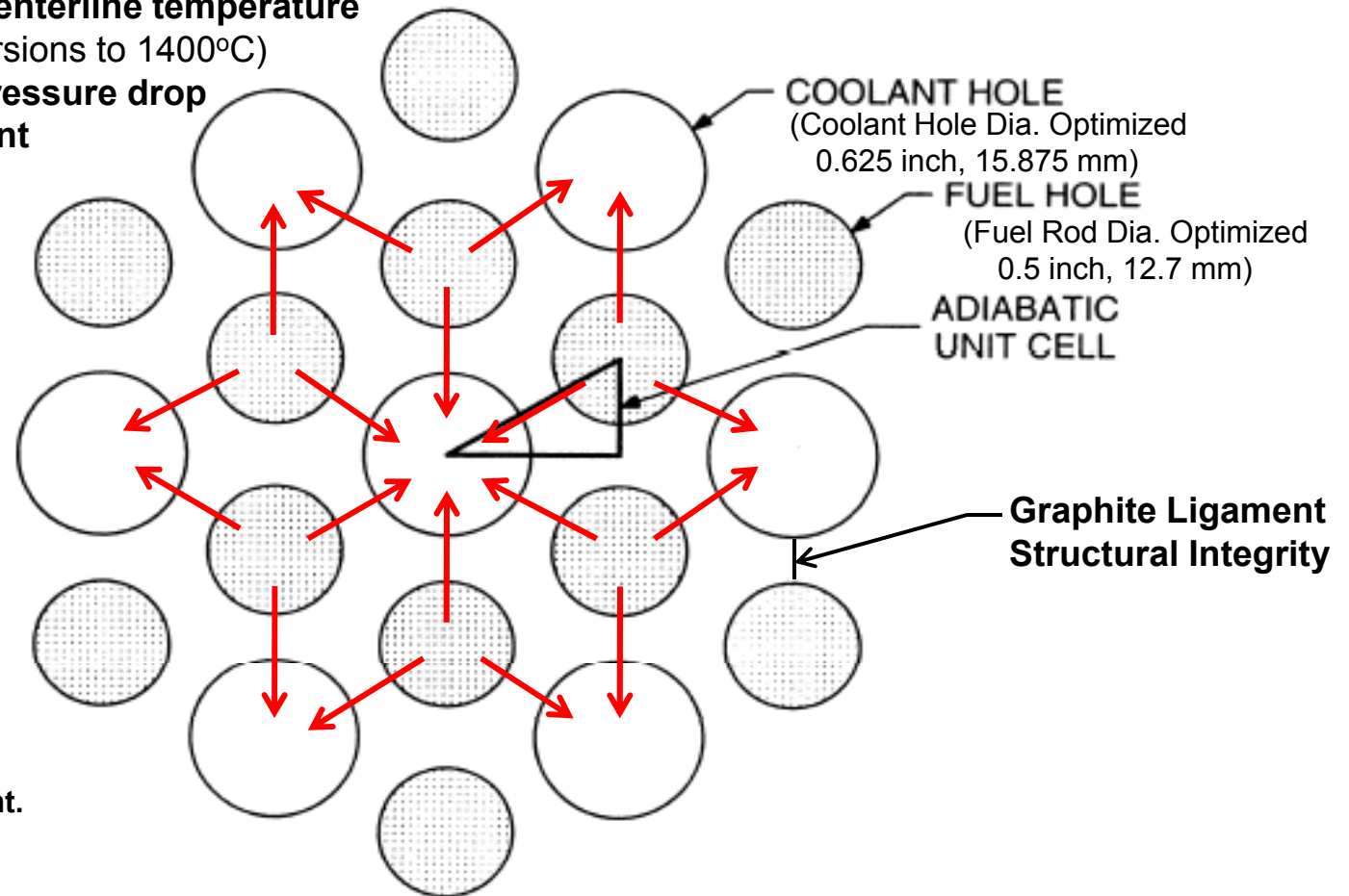

Graphite Fuel & Reflector Element

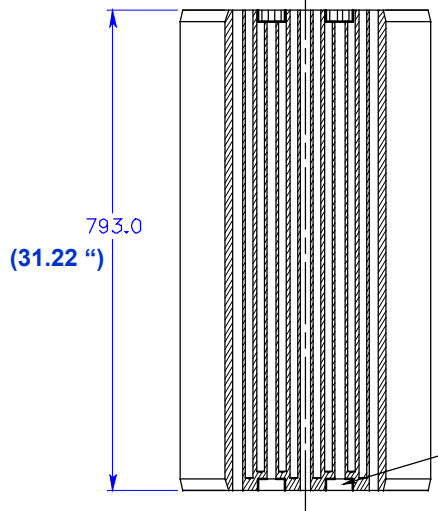
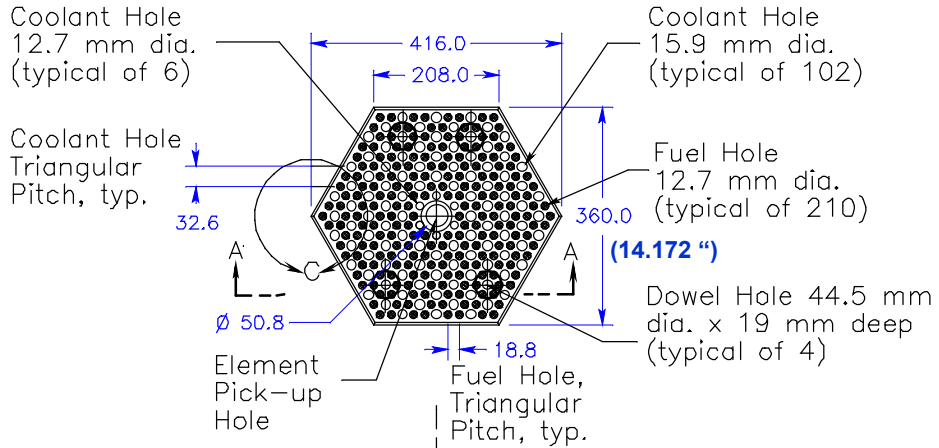

SECTION A-A

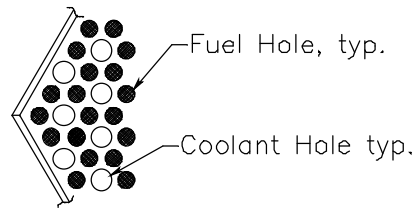

DETAIL C

Dowel Socket 44.5 mm dia. x 19 mm deep (typical of 4)

All Dimensions in mm

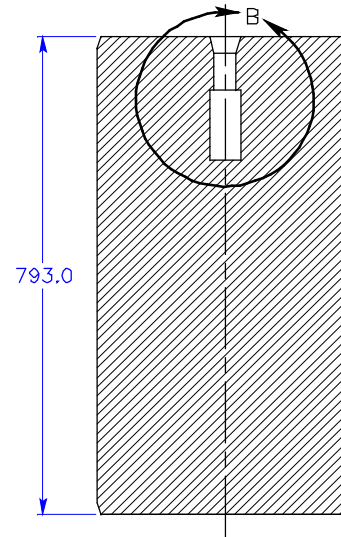
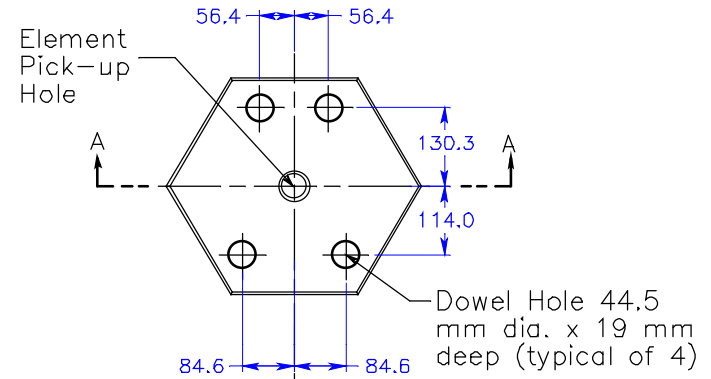

SECTION A-A

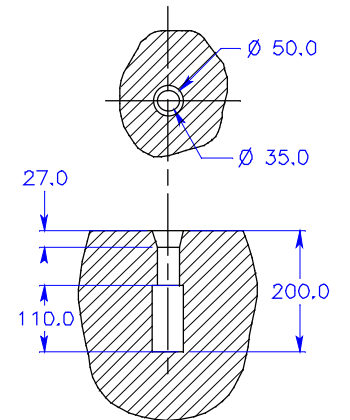

DETAIL B

Graphite Control Rod Elements

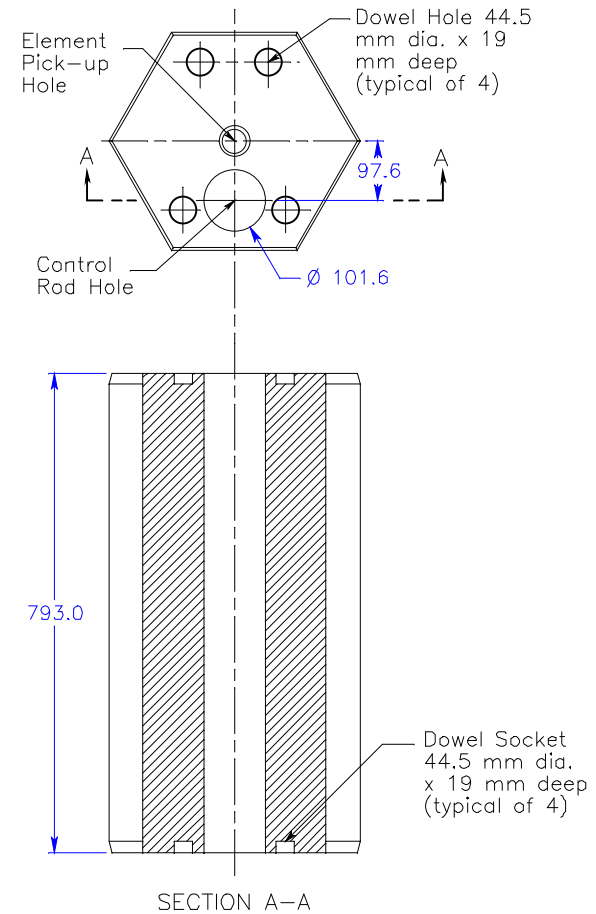
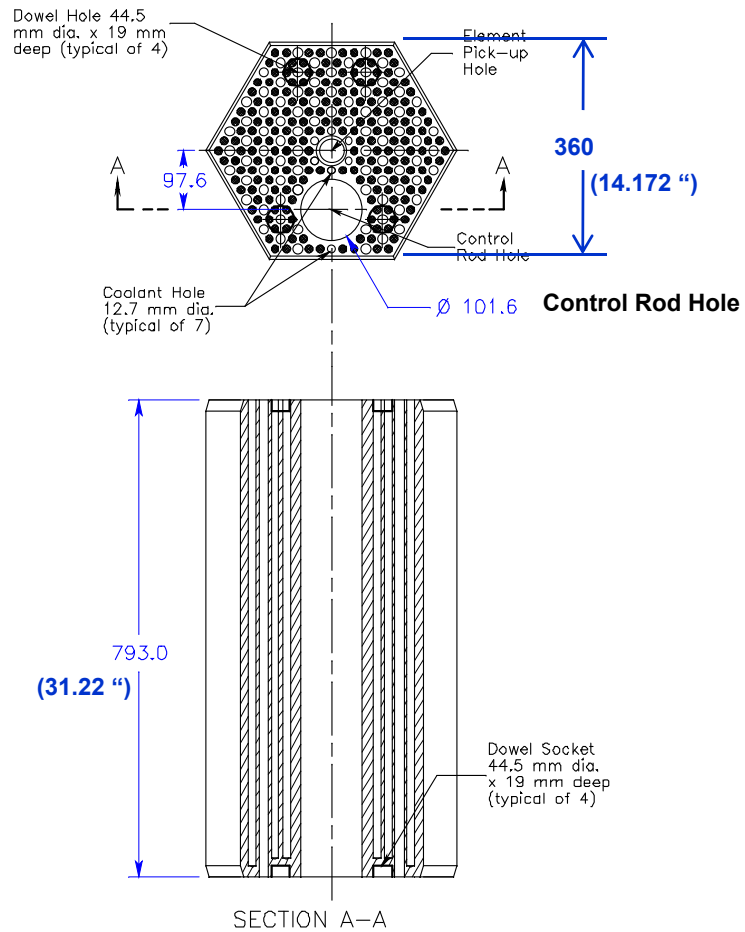

All Dimensions in mm

Upper Core Restraint Element

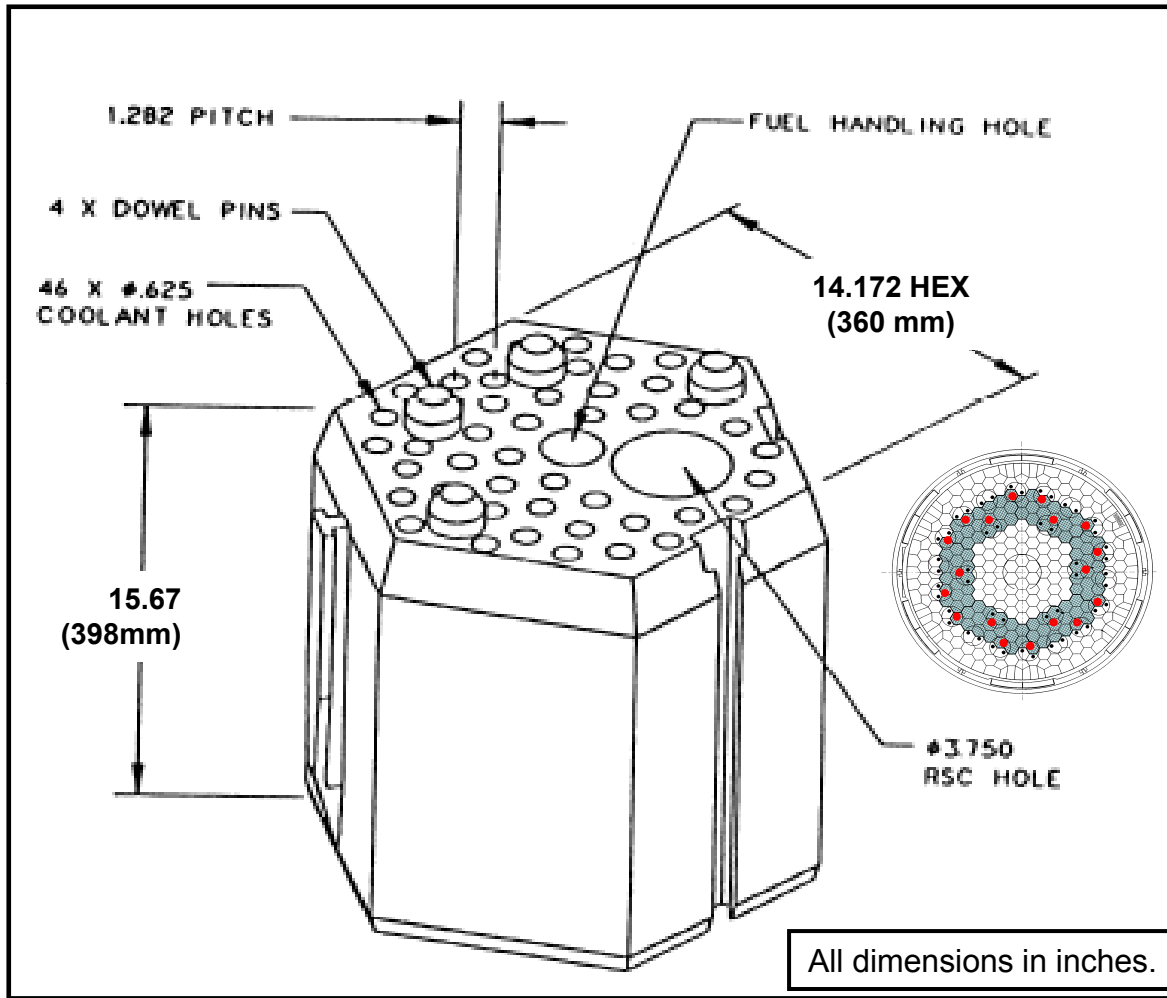

- “T” keys interlock elements
- Allow free thermal expansion of fuel column vertically and horizontally about fuel column centerline
- Restrains column centerline translation at top in horizontal direction
- Provides interface with control rod & RSM guide tubes
- Removed & replaced during refueling
- Material: Hastelloy XR (alternate: SiC/SiC or C/C composites)

Graphite Core Support Forms Exit Plenum and Provides Inspection/Surveillance Capability

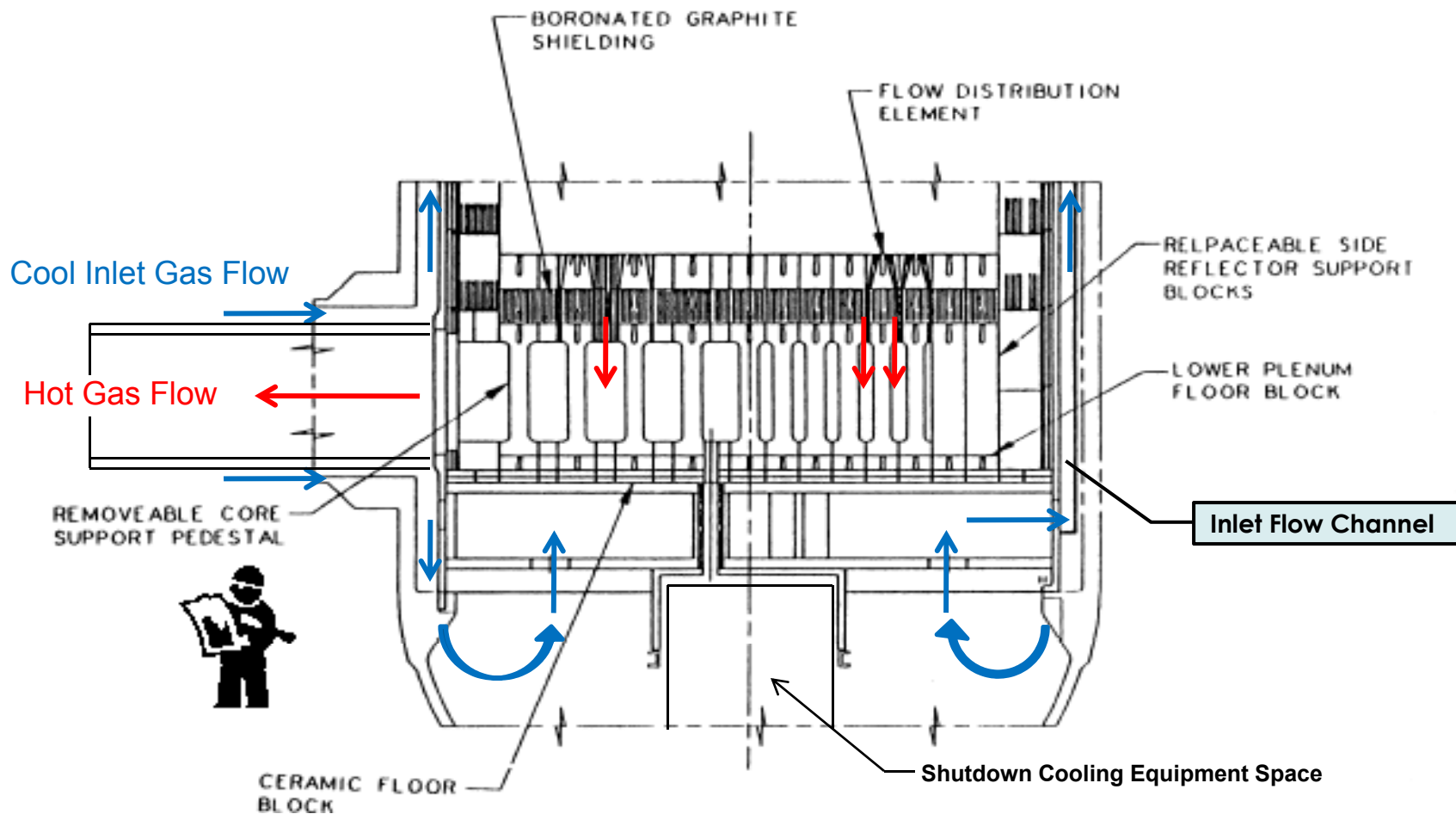

Reactor Core Assembled from Basic Units

- Material Graphite
- 102 Fuel Columns
- Hexagonal Fuel Block Dimensions:
 - Width Across Flats 0,36 m
 - Height 0,8 m
- Number of Fuel Blocks:
 - Standard 720
 - Control 120
 - Reserve Shutdown 180
- Number of Fuel Compacts 2919600
- Mass 870 tons

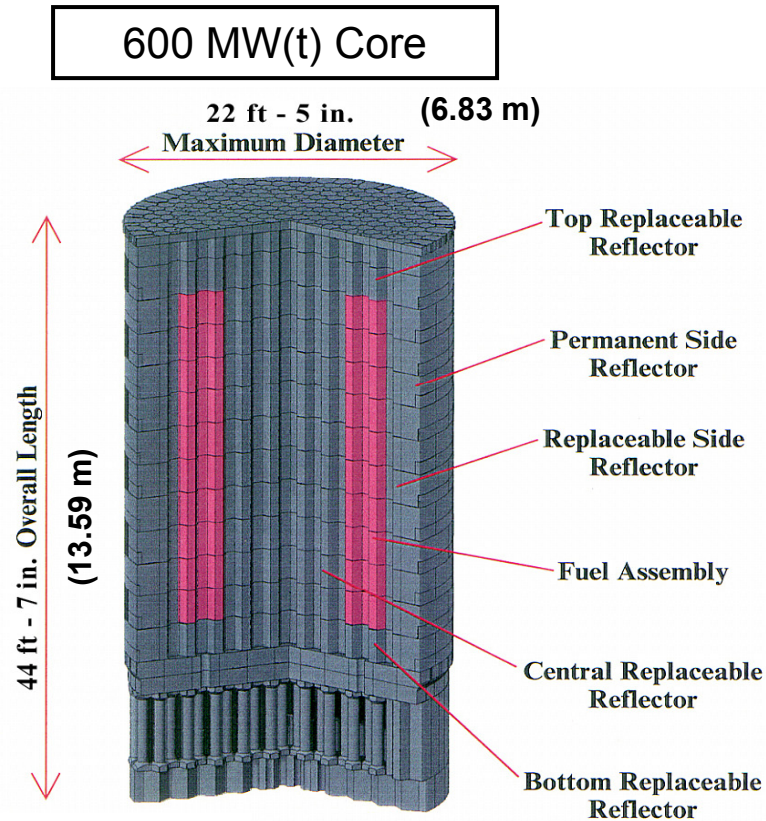

- Fuel assembly blocks stacked into columns and doweled together
- Gaps between graphite columns allow refueling
- Restrained vertically by metallic core support
- Core columns free to expand/contract vertically
- Restrained horizontally at top and bottom
- Contained by core barrel & bottom plate

Metallic Reactor Internals Structures Contain Graphite Core Assembly

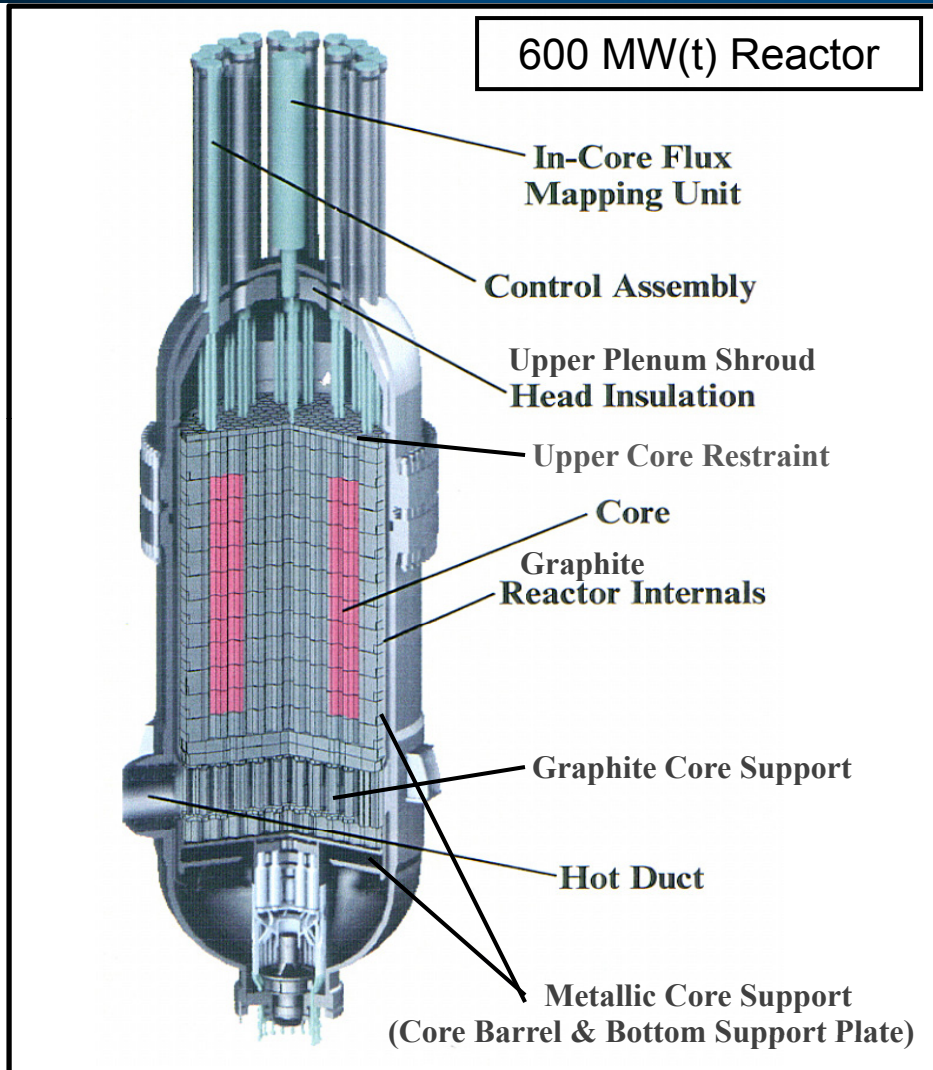

- Accommodates core thermal expansion/contraction
- Accommodates irradiation induced dimensional changes of graphite components
- Accommodates duty cycle transients
- Withstand 0.3g safety basis earthquake
- Operates for design life of 60 calendar years
- Provides for inspection & replacement of life-limited components

Engineering Analysis of Reactor Components

Purpose	Type of Analysis	Method	Codes
Core-Wide Thermal Hydraulics	Channel Flow with heat generation time history. Flow mixing.	Nodal Network Finite Element CFX	POKE SINDA/FLUINT RELAP5-3D ANSYS FLUENTN
Local Thermal-Hydraulics	Channel flow, heat generation, solid heat conduction time history	Finite Element	ANSYS
Local Stress	2-D & 3-D Solids with time history	Finite Element	ANSYS
Seismic	2-D & 3-D Dynamic Solid Bodies time history	Finite Element	ANSYS

Note: Material Models reflect the variation of properties with Temperature & Neutron Fluence

Reactor Component Limits

Component	Requirement	Basis												
Fuel	$\leq 1250^{\circ}\text{C}$ (Cycle Average) $\leq 1600^{\circ}\text{C}$ (Accident)	Fuel Integrity, Fission Prod Release												
Control Rods Upper Core Restraint	$\leq 927^{\circ}\text{C}$ (Sustained) $\leq 940^{\circ}\text{C}$ (Accident, cum ≤ 3000 h) $\leq \sim 1400^{\circ}\text{C}$ (Sustained) $\leq \sim 2000^{\circ}\text{C}$ (Sustained)	Hast XR allowable Temp SiC/SiC Ceramic Composite C/C Composite allowable Temp estimate												
Graphite Blocks	Temp Gradient ($\frac{dT}{dx}$) Temp $\leq 2100^{\circ}\text{C}$ (Sustained) Temp $\leq 2700^{\circ}\text{C}$ (Accident) Neutron Fluence $\leq \sim 8 \times 10^{25}$ n/cm ²	Stress (Structural Integrity) Stress, Chem attack, Irrad creep Stress, Chem attack Stress, Irrad induced dim chg, creep												
Core Array	Core Pressure drop $\leq \sim 70$ Kpa (~ 10 psi)	Flow-induced Vibrations												
Hot Duct	<table border="0"> <tr> <td><u>Sustained Temp</u></td> <td><u>Trans Temp (≤ 3000h)</u></td> </tr> <tr> <td>$\leq 760^{\circ}\text{C}$</td> <td>$\leq 871^{\circ}\text{C}$</td> </tr> <tr> <td>$\leq 899^{\circ}\text{C}$</td> <td>$\leq 938^{\circ}\text{C}$</td> </tr> <tr> <td>$\leq 927^{\circ}\text{C}$</td> <td>$\leq 940^{\circ}\text{C}$</td> </tr> <tr> <td>$\leq \sim 1400^{\circ}\text{C}$</td> <td>$\leq \sim 1600^{\circ}\text{C}$</td> </tr> <tr> <td>$\leq \sim 2000^{\circ}\text{C}$</td> <td>$\leq \sim 2400^{\circ}\text{C}$</td> </tr> </table>	<u>Sustained Temp</u>	<u>Trans Temp (≤ 3000h)</u>	$\leq 760^{\circ}\text{C}$	$\leq 871^{\circ}\text{C}$	$\leq 899^{\circ}\text{C}$	$\leq 938^{\circ}\text{C}$	$\leq 927^{\circ}\text{C}$	$\leq 940^{\circ}\text{C}$	$\leq \sim 1400^{\circ}\text{C}$	$\leq \sim 1600^{\circ}\text{C}$	$\leq \sim 2000^{\circ}\text{C}$	$\leq \sim 2400^{\circ}\text{C}$	<u>Temp Limits for T/B Cover Plates</u> Alloy 800H Hastelloy X Hastelloy XR SiC/SiC Ceramic Composite C/C Composite
<u>Sustained Temp</u>	<u>Trans Temp (≤ 3000h)</u>													
$\leq 760^{\circ}\text{C}$	$\leq 871^{\circ}\text{C}$													
$\leq 899^{\circ}\text{C}$	$\leq 938^{\circ}\text{C}$													
$\leq 927^{\circ}\text{C}$	$\leq 940^{\circ}\text{C}$													
$\leq \sim 1400^{\circ}\text{C}$	$\leq \sim 1600^{\circ}\text{C}$													
$\leq \sim 2000^{\circ}\text{C}$	$\leq \sim 2400^{\circ}\text{C}$													

Neutron Control

Key Requirements

- Provide two *independent and diverse* systems of reactivity control for reactor shutdown
- Each system shall maintain hot sub-criticality
- One system shall maintain cold shutdown during refueling conditions
- Provide neutron control system measurement and alarm
- Measure low, intermediate, and high range neutron flux
- Measure core axial and radial position neutron flux

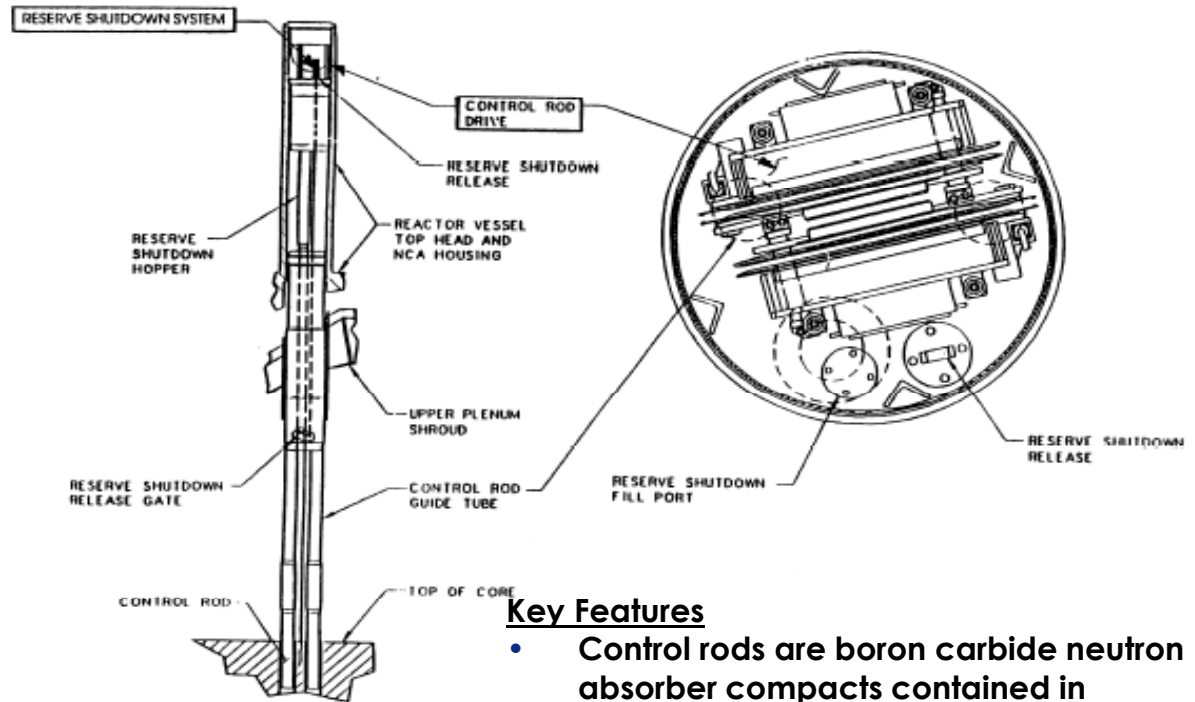

Key Features

- Control rods are boron carbide neutron absorber compacts contained in articulated structural cladding
- Each control rod supported by cable and drum drive
- Gravity control rod insertion
- Motor driven positioning
- Redundant control rod position sensors
- Redundant control rod cable force sensors
- Lumped Burnable poison used for local power shaping

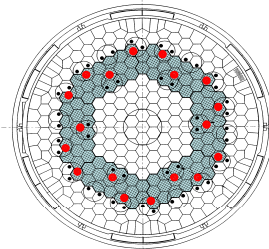

Control Rods Inserted into Top of Core

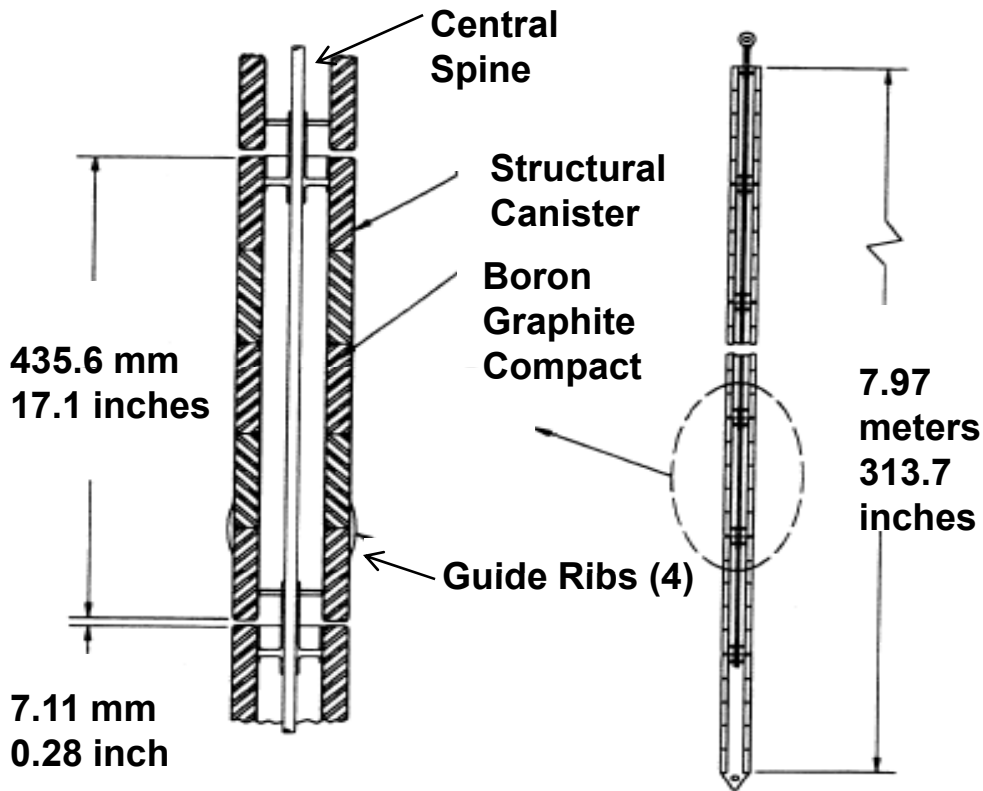

Note 1: Can hold out Inner control rods during a conduction cooldown event until core cools enough to insert inner rods.
 Note 2: Hastelloy XR is a slightly higher temperature version of Hastelloy X and needs to be added to the ASME Code.

- Absorber Mat'l: B₄C annular compacts
- Helium cooled along axis
- Gravity inserted
- Shock absorber at bottom end
- Outer rods required for emergency shutdown
- Inner rods only needed for cold shutdown ⁽¹⁾

Operating Conditions (°C) & Mat'l Selections (750 °C Core Outlet Temp)				
Component	Normal Operation	Pressurized Conduction Cool Down	De-press Conduction Cool Down	Mat'l
Inner Control Rod (Note 1)	808	1164	1418	Hast XR ⁽²⁾ C/C SiC/SiC
Outer Control Rod	440	929	980	Hast XR ⁽²⁾ C/C SiC/SiC
Guide Tubes (for Control Rods & Reserve Shutdown Material)	346	933	423	Hast X

Reserve Shutdown Neutron Absorber Pellets Dropped in Top of Core

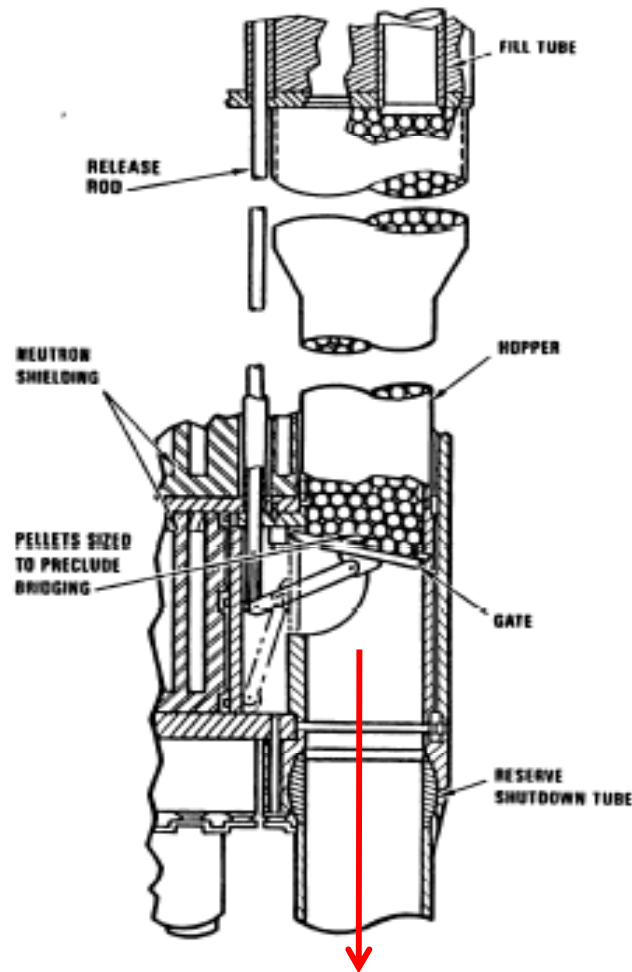

- Uses SiC/Pyrocarbon coated boron carbide pellets
- Pellet size: rounded cylinders, 14.2 mm (0.559 inch) diameter by 21.3 mm (0.839 inch) long

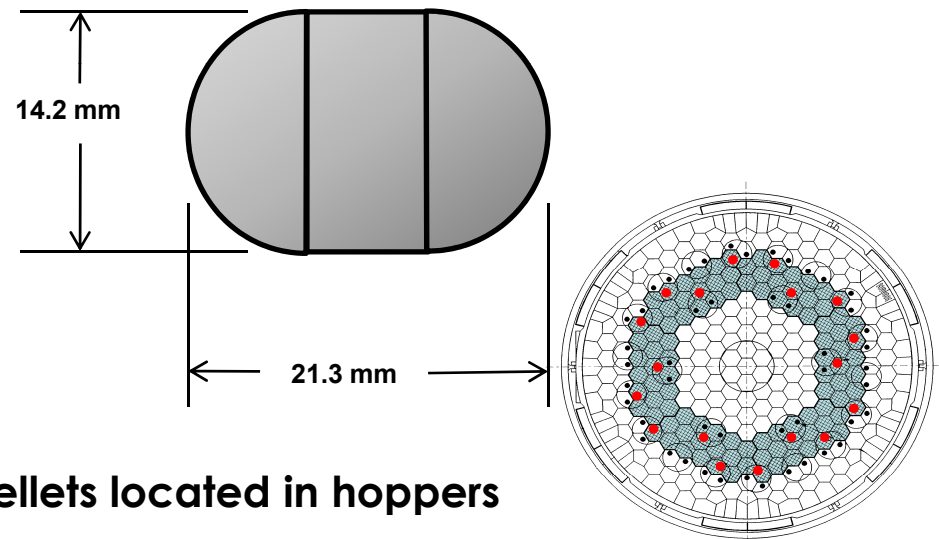

- Pellets located in hoppers
- Pellets gravity drop into core channels when hopper gate opens

Shutdown Cooling System (SCS)

SCS Protection System

Following detection of:

- Heat Exchanger Leaks
- Circulator Overspeed
- Low Cooling Water Flow
- Loss Of Net Positive Suction Head
- High Heat Exchanger temperatures

Actions:

- Shutoff Valve actuated
- Circulator shutdown

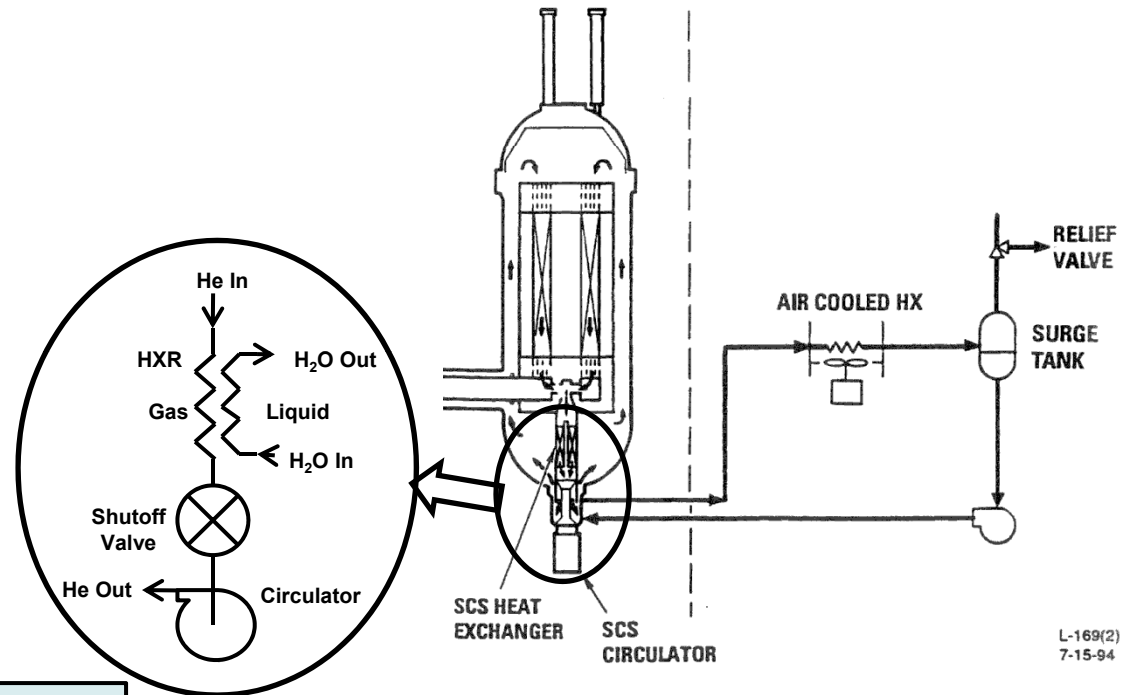

L-169(2)
7-15-94

Components List

- He Circulator
- He Shutoff Valve
- Gas to Liquid Heat Exchanger
- Control System
- Shutdown Water Cooling System
- Service Equipment

Single SCS Loop
per Reactor Module

Shutdown Cooling System Design Parameters

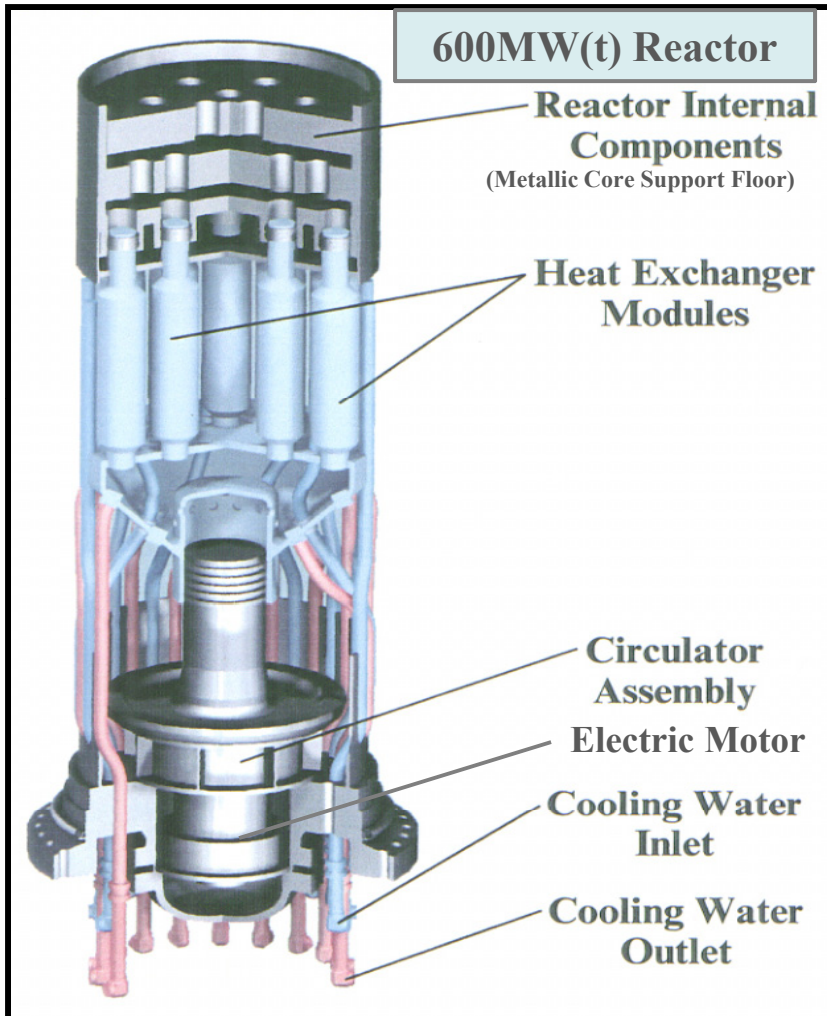

EQUIPMENT	Depressurized	Pressurized
<u>Shutdown Heat Exchanger</u>		
Design Heat duty	14.1 MW(t)	40 MW(t)
Helium inlet temperature	1032°C 1890°F	807°C 1485°F
Helium outlet temperature	179°C 355°F	341°C 645°F
Helium flow rate	3.21 kg/sec 25,438 lb/hr	14.51 kg/sec 115,200 lb/hr
Water flow rate	57.19 kg/sec 454,000 lb/hr	57.19 kg/sec 454,000 lb/hr
Water inlet temperature	60°C 140°F	60°C 140°F
<u>Shutdown Circulator</u>		
Motor power	323 kW 433 hp	TBD
Speed	6000 rpm	TBD
Exit pressure	84.1 kPa 12.2 psia	TBD
Inlet temperature	179°C 355°F	341°C 645°F
Helium pressure rise	6.14 kPa 0.89 psia	TBD
Helium flow rate	3.21 kg/sec 25,438 lb/hr	14.51 kg/sec 115,200 lb/hr

Outline

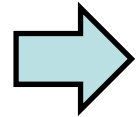

- **Core design description**
- **Cylindrical vs. annular core**
- **Coolant flow paths**
- **Central reflector options**
- **Effect of core outlet temperature on selection of materials**
- **Summary**

Reactor Power Changed by Arrangement of Basic Core Elements

1600°C Fuel Temperature Limit Determines Central Reflector Size

350 MW(t)

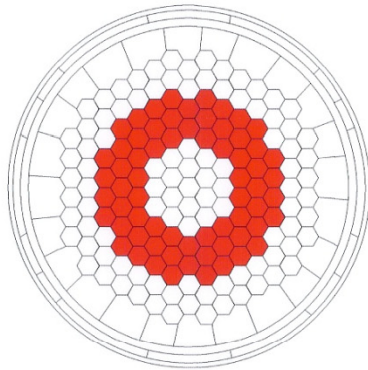

66 Columns
660 Elements
3.60 m Core Dia.
6.21 m Vessel Dia.
5.95W/cc
0.5303MW/FE

450 MW(t)

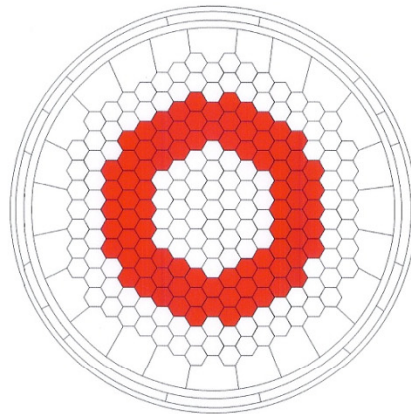

84 Columns
840 Elements
4.32 m Core Dia.
6.93 m Vessel Dia.
6.01W/cc
0.5357MW/FE

600 MW(t)

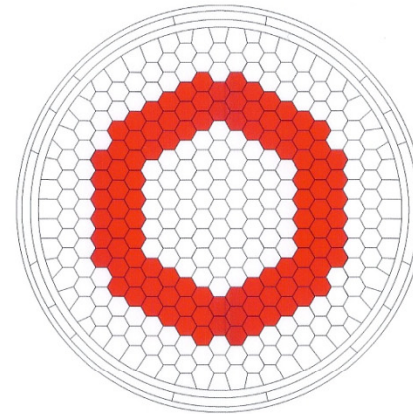

102 Columns
1020 Elements
5.04 m Core Dia.
6.93 m Vessel Dia.
6.60W/cc
0.5882MW/FE

Outline

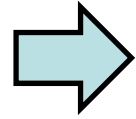

- Core design description
- Cylindrical vs. annular core
- Coolant flow paths
- Central reflector options
- Effect of core outlet temperature on selection of materials
- Summary

Modular HTGR Coolant Flow Path

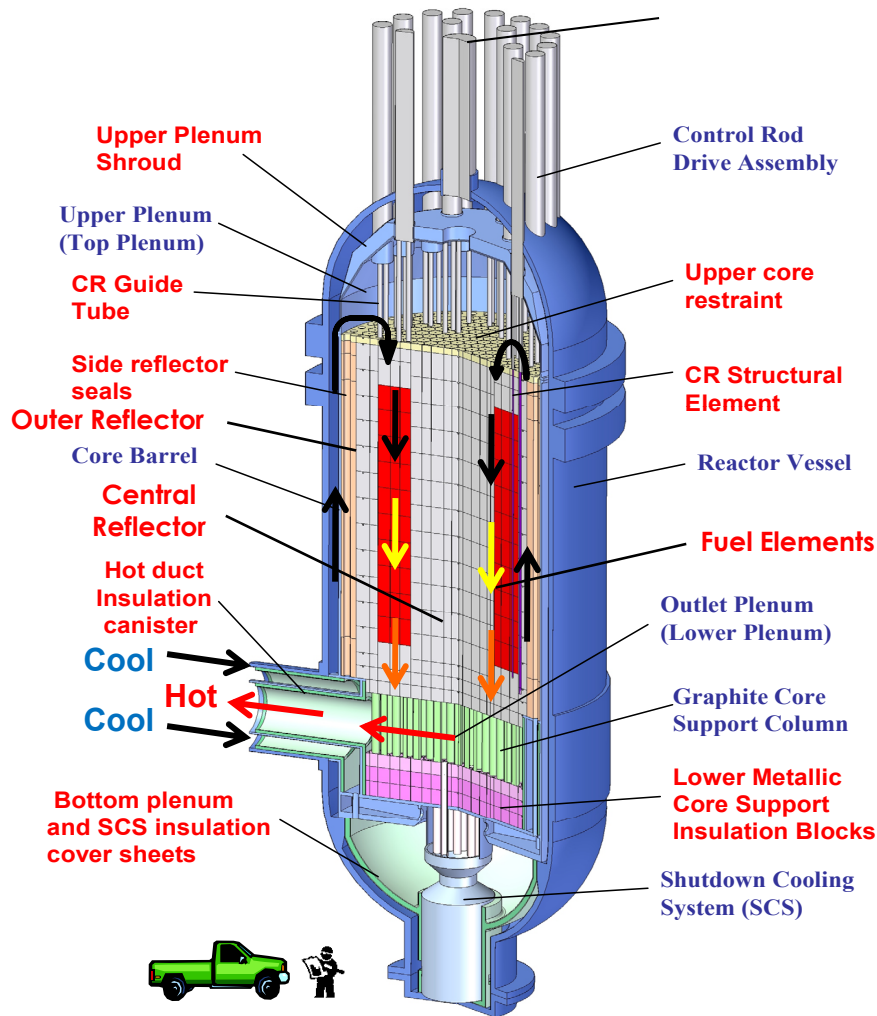

- **Inlet gas baths metallic pressure boundary**
 - Maintains boundary temperatures at gas inlet conditions during normal operation
- **Forced convection removes reactor heat**
 - Maintains temperatures at gas inlet conditions during normal operation
- **Hot gas collected in graphite lined lower plenum**
- **Hot duct guides gas to inlet of power conversion unit**
 - Cooled by core inlet gas
- **Return gas flow in annular region around hot duct**
 - Maintains cross vessel & hot duct structural sleeve at core inlet temperature

Outlet Gas Flow into Lower Plenum

- **Flow geometry**

- Fluid flow transitions from coolant holes to flow distribution elements
- Fluid flow exits as jets around support posts into lower plenum

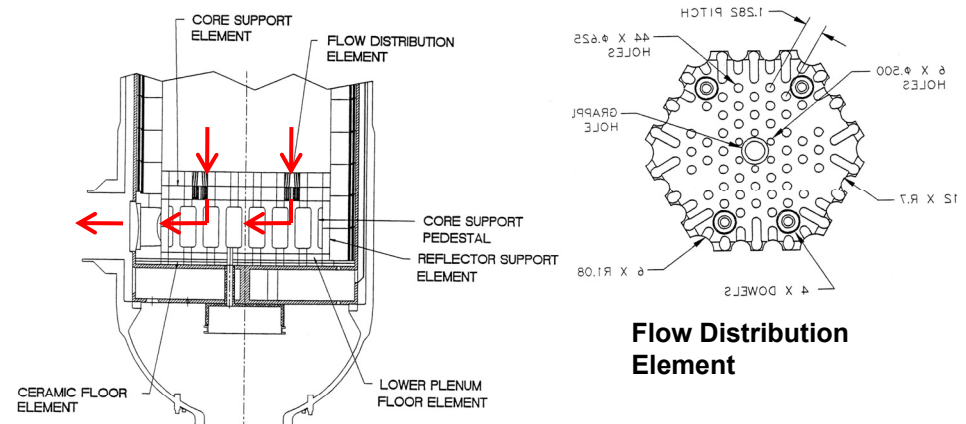

- **Flow phenomena**

- Many turbulent jets entering normal to the free stream flow
- A “forest” of support posts mixes gas streams of different temperature
- Complex 3-D mixing of jets
- Individual jet temperatures can be $\pm 200^{\circ}\text{C}$ of average plenum temperature
- Additional turbulent mixing in hot duct

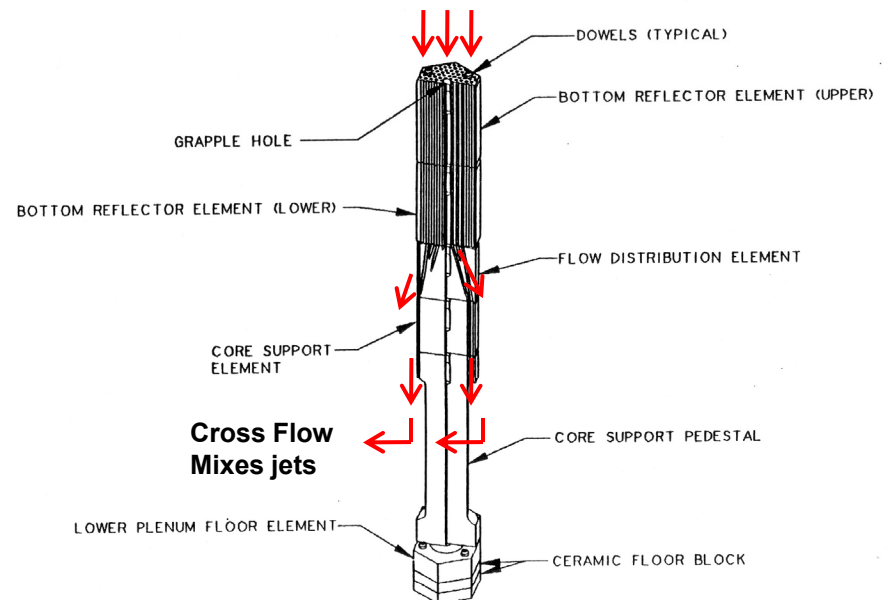

Metallic Reactor Internals

Guide Coolant & Support Reactor Core

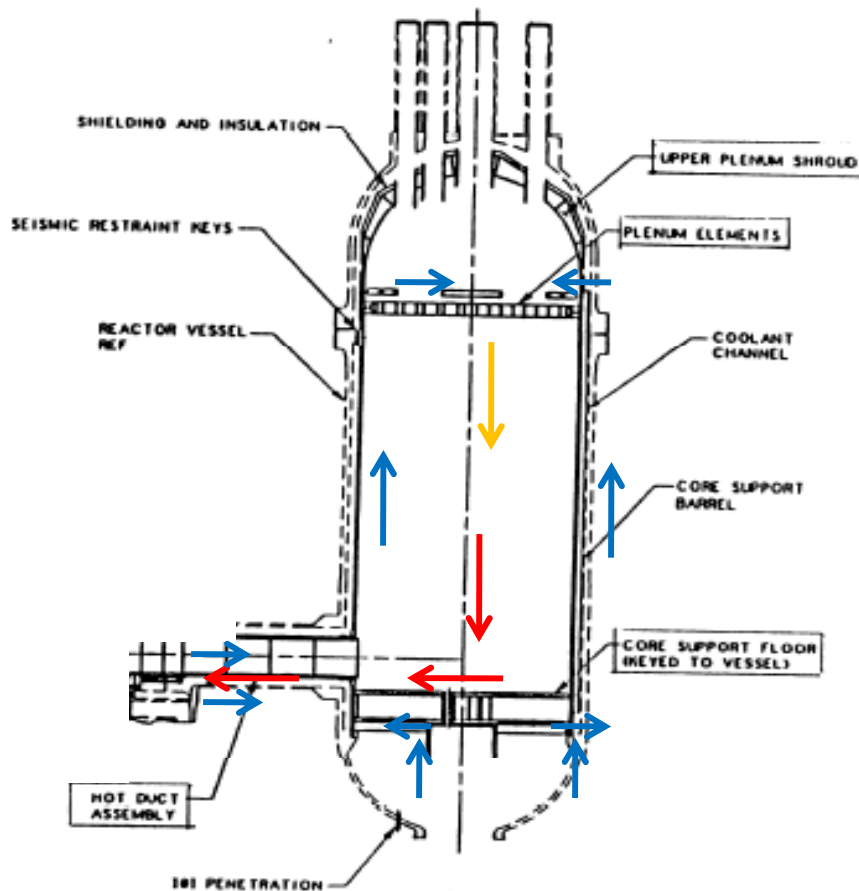

Operating Conditions & Material Selections (750°C Core Outlet Temperature)				
Component	Normal Operation (°C)	PCCD (°C)	DCCD (°C)	Material
Upper Core Restraint	346	1028	604	Hastelloy XR C/C SiC/SiC
Upper Plenum Shroud	318	877	455	800H Hastelloy X
Insulation Ceramic Lower Core Support	653	653	653	Macor Ceramic
Hot Duct and Lower Plenum Sidewall	Steady state 749 Steady state hot streak 786 Short term hot streak 820	749	749	Hastelloy X
Core Barrel, Lower Core Support, & Hot Duct Structures	350	~680	~734	Alloy 800H
PCCD = Pressurized Conduction Cooldown DCCD = Depressurized Conduction Cooldown				

Outline

- Core design description
- Cylindrical vs. annular core
- Coolant flow paths
- Central reflector options
- Effect of core outlet temperature on selection of materials
- Summary

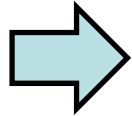

Central & Side Reflector Alternative Flow Paths

600MW(t)

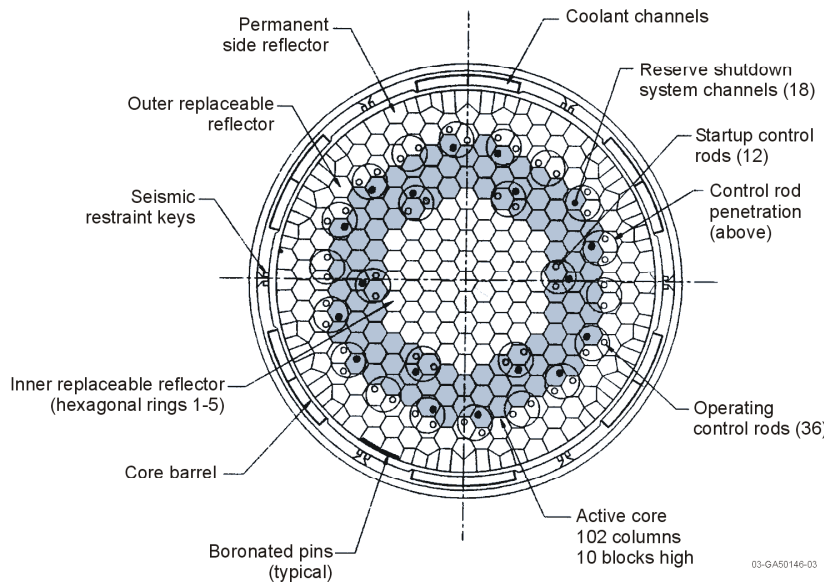

Inner Reflector

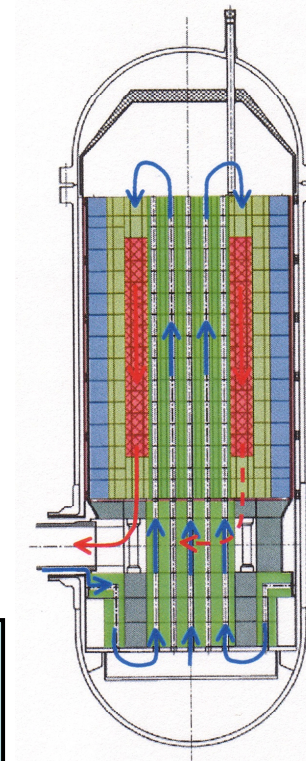

(a)

Permanent Side Reflector

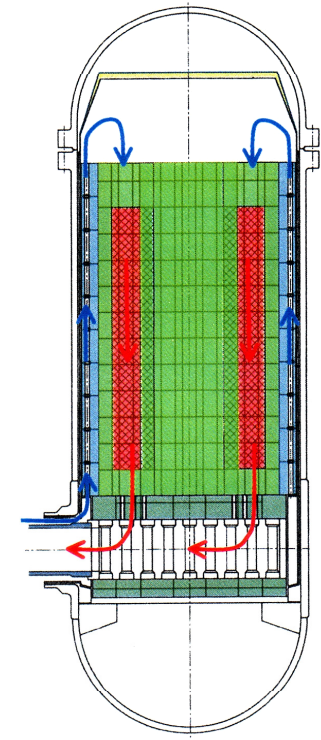

(b)

- Inner reflector flow channels
 - reduces central reflector heat capacity
 - increases fuel temperatures during accidents
- Outer Reflector flow channels
 - adds radial thermal resistance
 - Slightly increases fuel temperatures during accidents

Outline

- Core design description
- Cylindrical vs. annular core
- Coolant flow paths
- Central reflector options
- Effect of core outlet temperature on selection of materials
- Summary

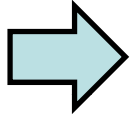

Raising Core Outlet Temperature Requires Materials with High-Temperature Capability

Material Temperature Limits		
Material	Long-Term Temperature Limit (°C)	Short-Term 3000 Hour Temperature Limit (°C)
Alloy 800H	760	871
Hastelloy X	899	938
Hastelloy XR	927	940
SiC-SiC	~ 1400	~ 1600
C-C	~ 2000	~ 2400

Different Materials Needed in Core & Upper Plenum as Core Outlet Temperature Increases

Component	Critical Condition	Core Outlet Temp Range (°C)	Component Max Temp (°C)	Limiting Temp (°C)	Material Selection	Temperature Limit Basis
Inner Control Rod	DCCD ⁽¹⁾	700 to 950	1413 to 1438	1600 or 2400	SiC/SiC Composite or C/C Composite	Estimate of 3000 hr maximum temperature limit. Needs confirmation.
Outer Control Rod	DCCD ⁽¹⁾	700 to 950	975 to 1000	1400 or 2000	SiC/SiC Composite or C/C Composite	Estimate of long term temperature limit. Needs confirmation.
Guide Tubes for Control Rods & Reserve Shutdown Material	PCCD ⁽²⁾	700 to 800	928 to 938	938	Hastelloy X	Extrapolation of S _t for 3000 hr at maximum temperature
		850 to 950	943 to 953	1400	SiC/SiC Comp	Estimate of long term temperature limit. Needs confirmation.
Upper Core Restraint	PCCD ⁽²⁾	700 to 950	1023 to 1048	1400 or 2000	SiC/SiC Composite or C/C Composite	Estimate of long term temperature limit. Needs confirmation.
Upper Plenum Thermal Barrier	PCCD ⁽²⁾	700 to 950	872 to 897	899	Hastelloy X	Long term temperature limit in ASME Code Section VIII

Note 1. DCCD stands for "Depressurized Conduction Cool Down" event.

Note 2. PCCD stands for "Pressurized Conduction Cool Down" event.

Different Materials Needed in Lower Plenum as Core Outlet Temperature Increases

Component	Critical Condition	Core Outlet Temp Range (°C)	Component Max Temp (°C)	Limiting Temp (°C)	Material Selection	Temperature Limit Basis
Hot Duct Thermal Barrier	Hot Streak Transients during Normal Op.	700	766	871	Alloy 800H	Extension of S _t curves for 3000 hr at maximum temperature
		750 to 850	820 to 923	938	Hastelloy X	Extension of S _t curves for 3000 hr at maximum temperature
		900 to 950	972 to 1022	1400 or 2000	SiC/SiC Composite or C/C Composite	Estimate of long term temperature limit. Needs confirmation.
Lower Plenum Sidewall Thermal Barrier	Sustained Hot Streak during Normal Op.	700 to 800	664 to 750	760	Alloy 800H	ASME Code limit
		850 to 950	791 to 871	899	Hastelloy X	Long term temperature limit in ASME Code Section VIII
Shutdown Cooling System Entrance Tubes Thermal Barrier	Sustained Hot Streak during Normal Op.	700 to 800	664 to 730	760	Alloy 800H	ASME Code limit
		850 to 950	768 to 844	899	Hastelloy X	Long term temperature limit in ASME Code Section VIII
Shutdown Cooling System Thermal Barrier	Normal Op. Core Inlet Temp	750 to 950	350	760	Alloy 800H	ASME Code limit

Outline

- Core design description
- Cylindrical vs. annular core
- Coolant flow paths
- Central reflector options
- Effect of core outlet temperature on selection of materials
- Summary

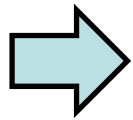

Summary

- **Prismatic HTGR core & internals are fabricated as standard units which can be arranged to suit the power level of the reactor**
- **Standard assemblies can be tailored to reduce power peaks and control temperatures during operation and accidents**
- **All standard assemblies are designed for easy removal and replacement for in-service inspection and examination at selected refueling intervals**
- **Annular core maintains fuel at safe temperature during accidents**

Summary

- **Use of high-temperature materials enables the MHTGR to operate at high core outlet temperatures during normal operation and accident transients with good margins of safety**
- **High-temperature capability of graphite components containing ceramic fuel and structural elements assures:**
 - **Core geometry stable and well defined at high temperature**
 - **Fuel, moderator, lumped burnable poisons, control rods/reserve shutdown coolant geometry are maintained throughout credible accidents such as conduction cool down events**

Suggested Reading

- **Effect of Reactor Outlet Helium Temperature on the Need for Composites in the NGNP, GA Report 911175, Rev. 0, June 11, 2009**